

The Quality Leader in Maritime Communication High Performance and Quality

With more than 25 years experience in developing Inmarsat terminals, and more than Inmarsat terminals delivered, we know what it takes to meet the extreme environmental demands of the sea. Maritime communication has changed over the years, from telex, and telephone, to High Speed data gateways. The New FLEET 77 from JRC, incorporates cutting edge technology, flexible interfacing, and the familiar Windows Operating System, ensuring reliable and user-friendly operation.



Major Specifications

- | | | |
|--|--|--|
| <ul style="list-style-type: none"> ● Frequency range
Transmit : 1626.5~1660.5MHz
Receive : 1525.0~1559.0MHz
Channel Spacing: 1.25KHz ● E.I.R.P.: +32 +1/-2 dBW Max. ● G/T: -4dB/K or more ● Modulation
BPSK : 3Kbps
16QAM : 64Kbps | <ul style="list-style-type: none"> ● Antenna
Type : 0.89m φ parabolic
Polarization : Right-hand circular
Beam : 15° at 3dB down
Enclosure : 1.38m φ radome
Roll +/-30deg./s
Pitch +/-10deg./6sec
Yaw +/-8deg./s, Turning 6deg./s | <ul style="list-style-type: none"> ● Primary power
Voltage : AC100/110,200/220V ±10%
Frequency : 50/60Hz ±6% ● Environmental conditions
Temperature : -25~+55°C(ADE)
-15~+55°C(BDE)
Humidity : Up to 95%
(40°C Relative) |
|--|--|--|

Standard Components

Above Deck Equipment (ADE)
Below Deck Equipment (BDE)
Telephone
ADE-BDE single coaxial cable (Cable length: 50m)

JRC Supplied :
Remote telephone
G3 facsimile
Buzzer box
Voice distress button
Card reader
Card reader interface
Wide band FR interface

Options

Customer Supplied :
Personal Computer (WindowsXP/2000)
G4 facsimile
Router
Video Phone etc.

Standard Functions

Voice (4.8K Voice/64K Speech)
Data (64K/56K UDI, MPDS)
Facsimile (64K Audio:G3, 64K UDI:G4)

Dimensions & Weight

● Above Deck Equipment(ADE)

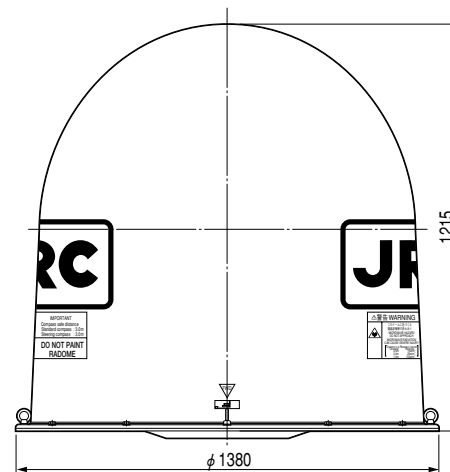

Mass: 80kg approx.

● Below Deck Equipment(BDE)

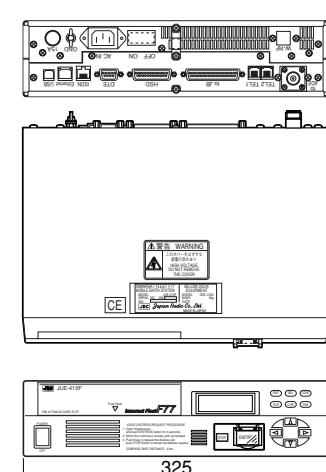

Mass: 5kg approx.

● Telephone

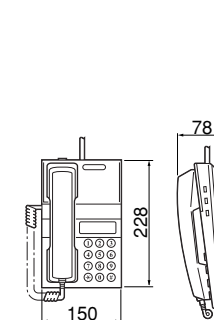

Mass: 0.7kg approx.

⚠ Cautions for Safety

- Read the Instruction Manual before your use for safety in operation.
- Do not install this equipment in a place with water, wetness, vapor, dust and oily smoke. Otherwise, a fire, electric shock or failure may result.
- For the installation work for this equipment, request to JRC agents or dealers. The installation work done by any non-specialist personnel may result in an electric shock or failure.
- The appearance and dimensions of the equipment may be subject to change without notice.

For further information, contact:

JRC Japan Radio Co., Ltd.
Since 1915 URL <http://www.jrc.co.jp/>

Main Office: Nittochi Nishi-Shinjuku bldg.
10-1, Nishi-Shinjuku 6-chome
Shinjuku-ku, Tokyo 160-0023, Japan
Telephone: +81-3-3348-4099
Facsimile: +81-3-3348-4139

Overseas Branches : Seattle, Amsterdam
Liaison Offices : Taipei, Manila, Jakarta, New York,
Piraeus

22EM ISO9001, ISO14001 Certified
© 2003.10 C2003.10 CAT.No.Y14-192 (No.729-1-5) A Printed in Japan

JRC



Fleet F77 Maritime Satellite Communication Terminal JUE-410F

Inmarsat Certification No. 66JR01



Japan Radio Co., Ltd.

Advanced functions for networking are integrated in compact design.

Interface & Operation

Networking support with a variety of interfaces

JRC's JUE-410F is the world's first Inmarsat Fleet Mobile Terminal with built-in Ethernet interface. The new Fleet 77 incorporates a wide range of standard interfaces, such as Ethernet, RS-232 serial, ISDN and USB. These interfaces allow flexible on-board networking. Built-in Web Server function enables easy operation by PC.

- ◆ Easy to connect PC with standard interfaces like Ethernet and RS-232.
- ◆ Easy access to Internet with built-in terminal adapter.
- ◆ Easy web access operation with built-in web server function.



High-Speed Data Services

Two types of high-speed data service

JRC's JUE-410F supports two types of 64kbps data service. Mobile Packet Data Service (MPDS) and High Speed Data Service (HSD). By selecting the appropriate service it enables you to use the most cost effective solution for any kind of communication

- ◆ MPDS : Web browsing, Emailing, Chat communication, etc.
- ◆ HSD : Digital image transmission, Videophone, Chart Collection, etc.



The JUE-410F's all-in-one design provides superior quality, easy installation, user-friendly operation and heavy-duty construction.

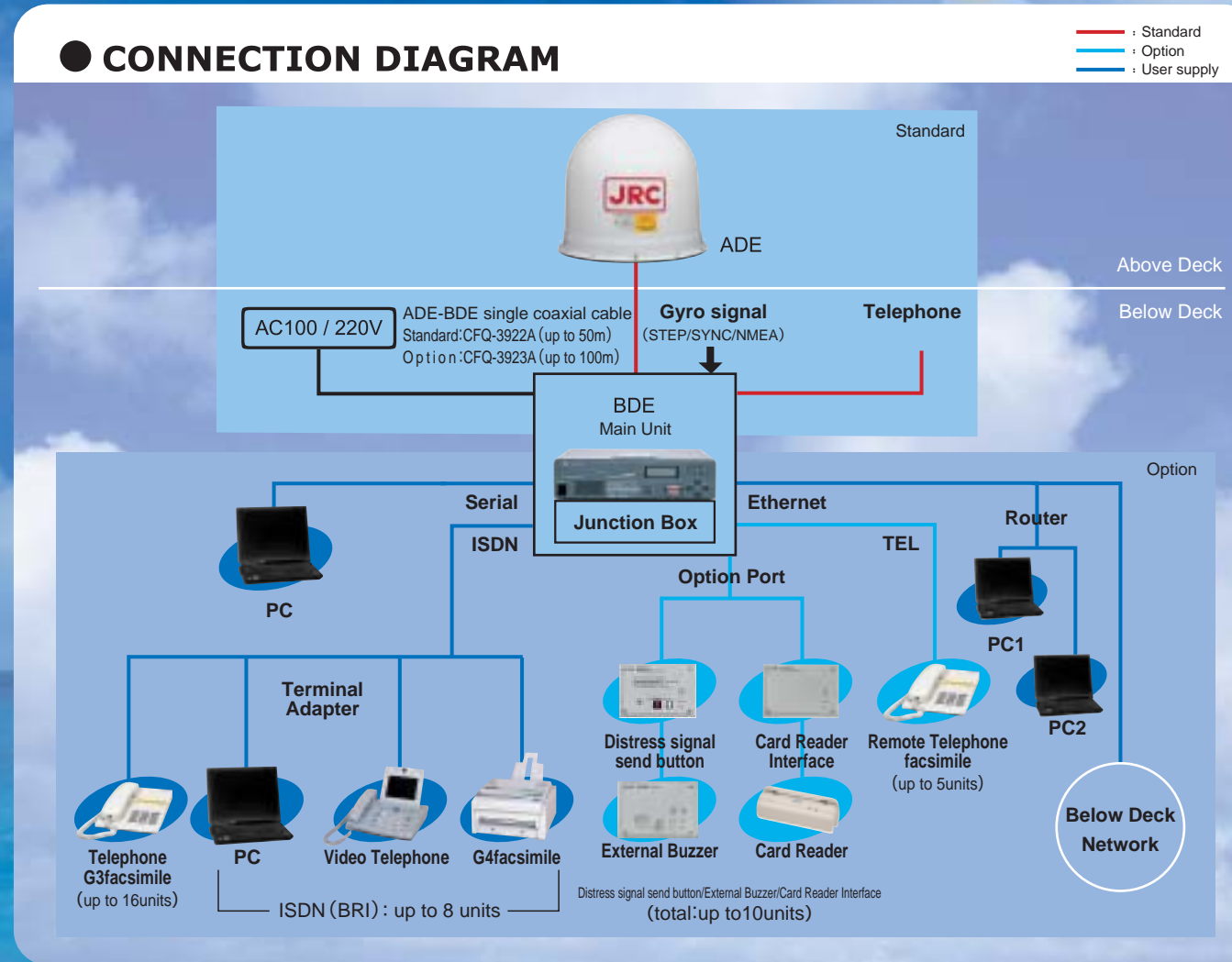

The Fleet F77 JUE-410F maritime satellite communication terminal station is designed according to JRC's proven high quality standards.

It is user-friendly, easy to install, and the antenna is the most rugged in the Inmarsat market. JUE-410F provides voice (normal and high quality), G3 & G4 FAX, up to 64Kbps MPDS (Mobile Packet Data Service) communication, and up to 64Kbps HSD (High-Speed Data) communication, as standard.

Advanced Features;

- ◆ "All-in-one" design, including a comprehensive line of interfaces for high flexibility in operation.
- ◆ Modern user-friendly windows based operation.
- ◆ JRC's unique design of antenna (ADE), recognized for very high reliability.
- ◆ The BDE (below deck equipment) comes with Ac power supply as standard.
- ◆ Dedicated mechanical / electrical interfaces for upgrading from Inmarsat-A/B to Fleet F77.
- ◆ Voice Distress Communication (Distress button protected from unintended transmission with cover).

High Reliability

JRC's Unique Antenna Design

JRC's JUE-410F Antenna is designed using the latest structural design methodology, incorporating analysis from ship's motion and vibration data, collected from a wide range of vessels.

JRC's long established experience in Inmarsat antenna design – dating back to the late 70's - has resulted in:

- ◆ High reliability antenna for merchant vessels to middle-small size fishing boats.
- ◆ Easy installation by connecting the ADE and BDE with one coaxial cable. (Up to 100m)

World-wide Support

With reliable JRC customer support

The JUE-410F is equipped with a self-diagnostics function making troubleshooting and repair simple. JRC's service network can analyze the failure by using a self-diagnostics data, providing fast, reliable response. JRC's worldwide support network with 60 countries and 165 ports guarantees strong support.